

# Lift Truck Operator Training



**Operator  
Qualifications  
Scheme**

a training accreditation organisation



# Lift Truck Operator Training

Course Instructor

**Instructor Name**

Course Type

**Basic Operator  
Training**

an accredited training provider



# Lift Truck Operator Training

Course Instructor

**Instructor Name**

representing

**Training Provider Name**

an accredited training provider



# SAFETY AND WELFARE INFORMATION



**Fire Alarm, Tests and Evacuation**



**Welfare Facilities**



**Breaks and Refreshments**



**Phones**

# Lift Truck Operator Training

## Lift Truck Stability or Lift Truck *In-Stability*



# Lift Truck Stability

A lift truck's design is based on the seesaw principle. If the weights of "A" and "B" are equal (fig 1) and are placed at an equal distance from the fulcrum, the seesaw will balance.

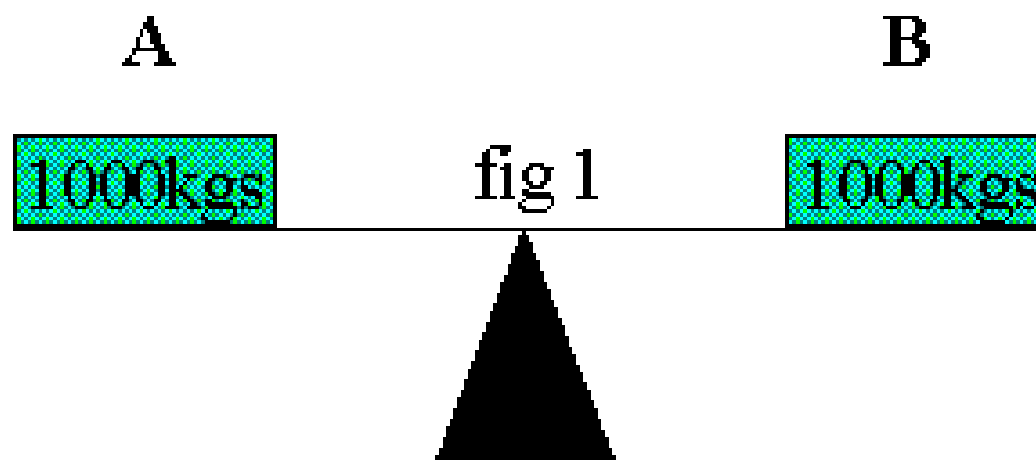

# Lift Truck Stability

However if the weight of “B” is increased while “A” remains the same (fig 2) then the weight “B” must be moved closer to the fulcrum in order to maintain balance.

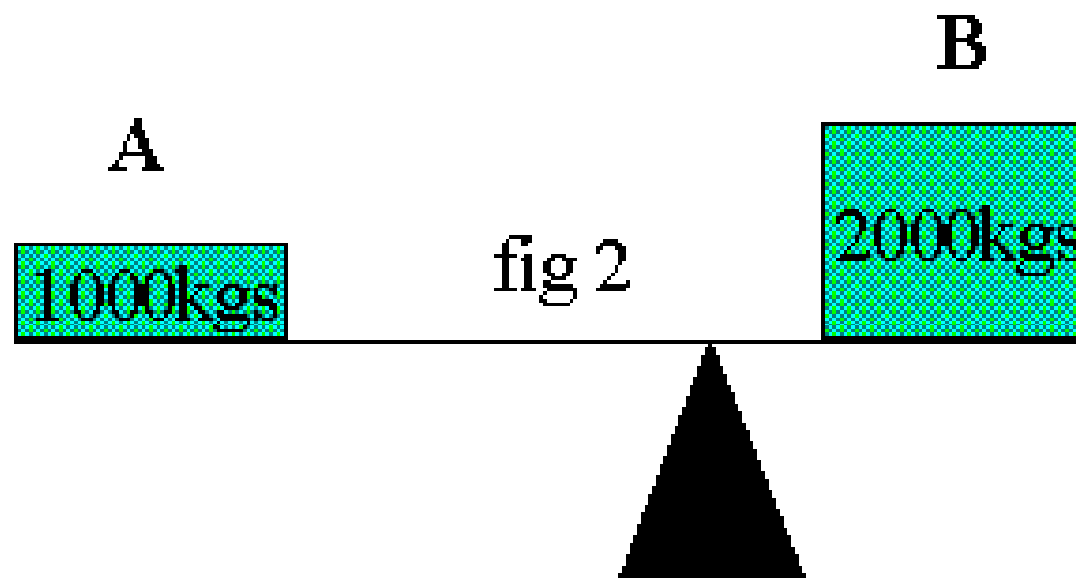

# Lift Truck Stability

The fulcrum on the lift truck is the centre of the front wheels. If the load exceeds that stated on the lift truck rating plate the lift truck will become unstable and could tip forwards.

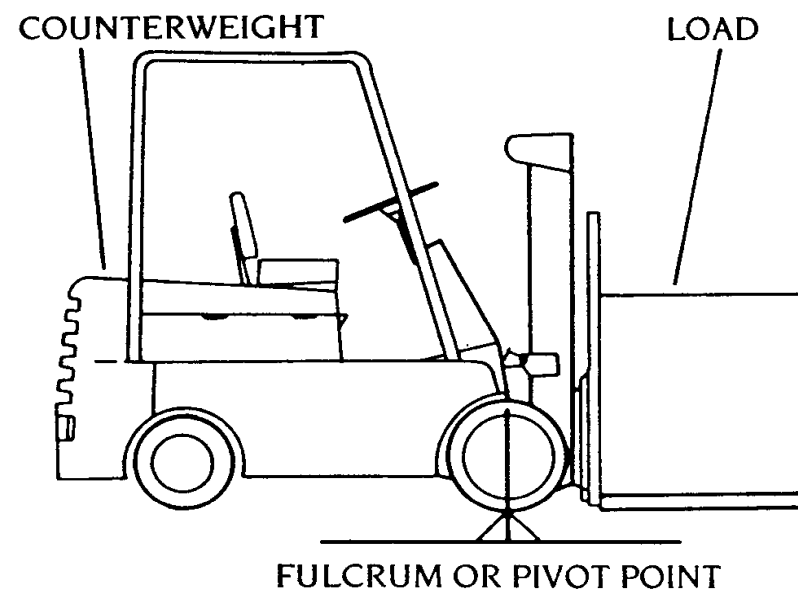

# Rated Capacity Plates & Safe Working Loads

**Lift trucks should not be loaded beyond their safe capacity.**

The weight of the counterbalance (i.e., the truck itself) should not be increased in attempt to lift heavier loads, as this will have an adverse effect on Stability and safety.

# Rated Capacity Plates & Safe Working Loads

## The WEIGHT:

What the lift truck can safely lift.

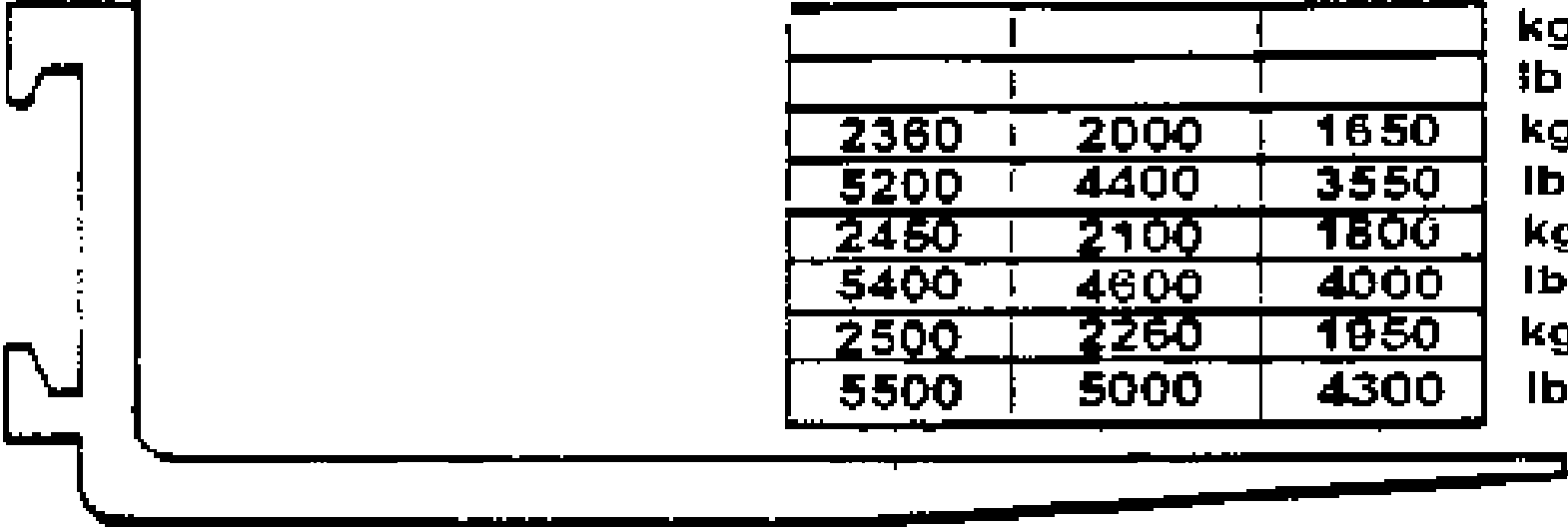

Load			
			kg
			lb
2360	2000	1650	kg
5200	4400	3550	lb
2450	2100	1800	kg
5400	4600	4000	lb
2500	2250	1950	kg
5500	5000	4300	lb

# Rated Capacity Plates & Safe Working Loads

## The WEIGHT:

Exceed the weight the lift truck can safely lift it will lose forwards stability possibly causing the lift truck to tip forward.

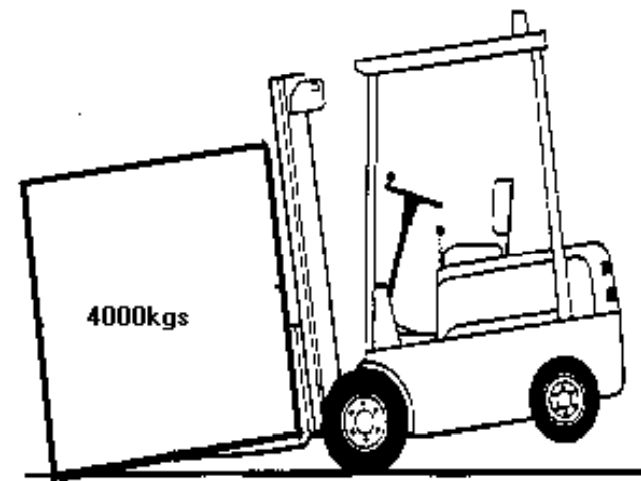

# Rated Capacity Plates & Safe Working Loads

## The Load Centre:

A distance measured from the vertical face of the forks to the centre point of gravity of the load.

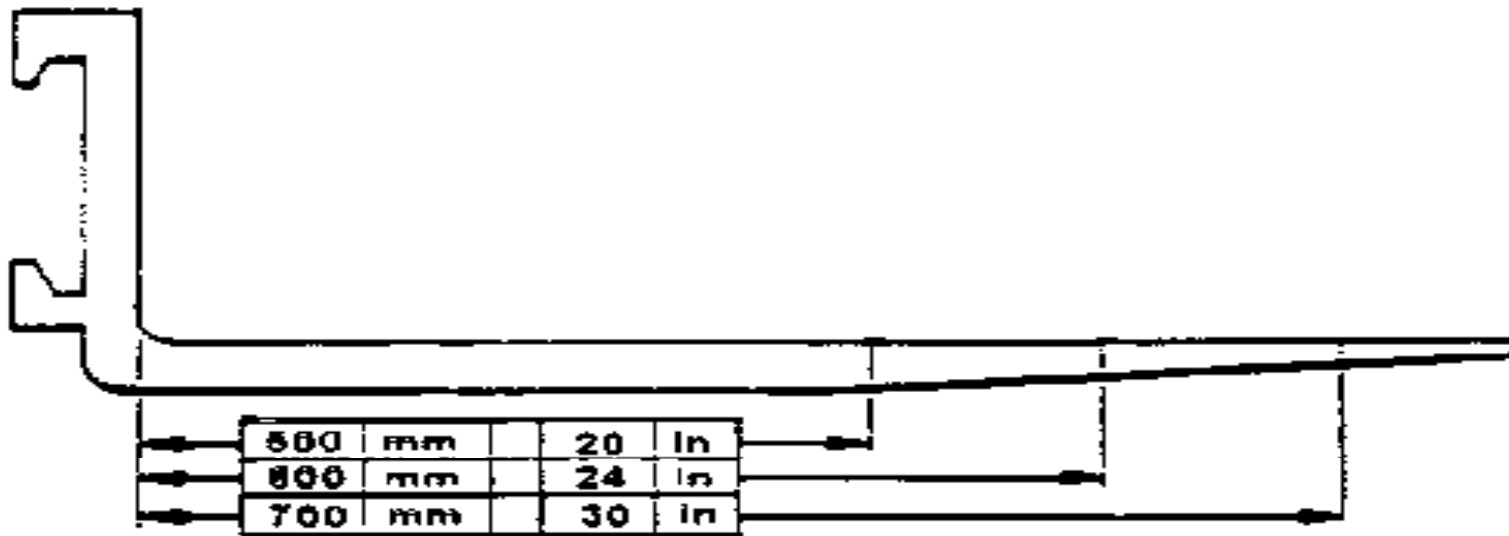

# Rated Capacity Plates & Safe Working Loads

## The Load Centre:

Exceed the load centre to weight ratio the lift truck will lose forwards stability possibly causing the lift truck to tip forward.

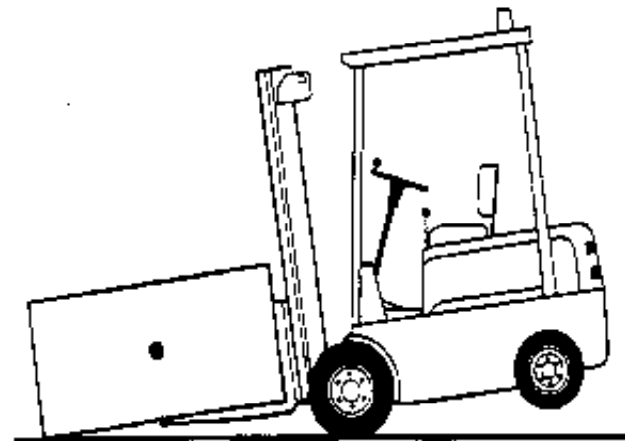
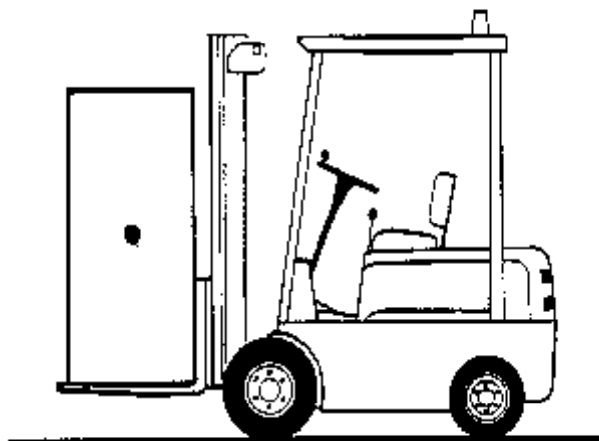

# Rated Capacity Plates & Safe Working Loads

## The Lift Height:

The height the forks will lift a weight to.

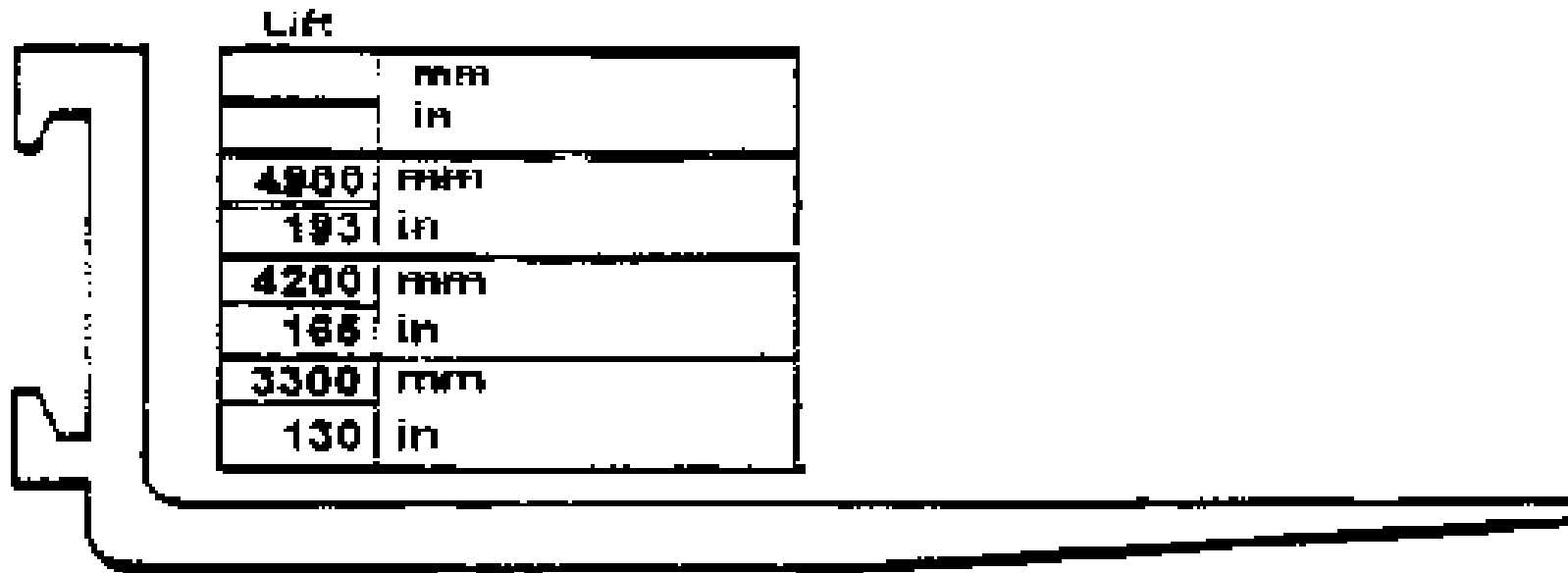

Lift	
	mm
	in
4800	mm
193	in
4200	mm
165	in
3300	mm
130	in

# Rated Capacity Plates & Safe Working Loads

## The Lift Height:

Exceed the height to weight ratio the lift truck will lose forwards stability possibly causing the lift truck to tip forward.

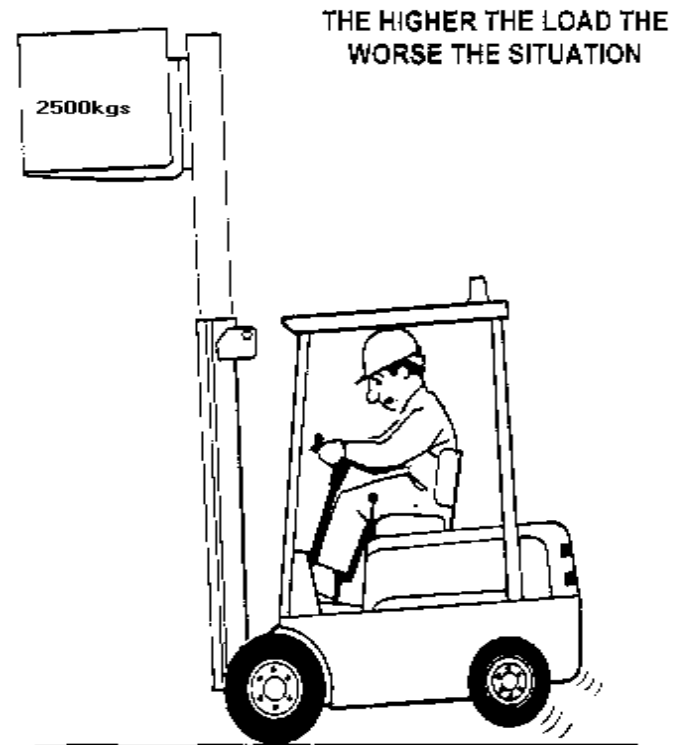

# Rated Capacity Plates & Safe Working Loads

**WARNING - DO NOT OVERLOAD**

Lift	Load			kg	
	mm				lb
4900	mm	2360	2000	1650	kg
193	in	5200	4400	3550	lb
4200	mm	2450	2100	1800	kg
165	in	5400	4600	4000	lb
3300	mm	2500	2260	1950	kg
130	in	5500	5000	4300	lb

500	mm	20	In
600	mm	24	In
700	mm	30	In

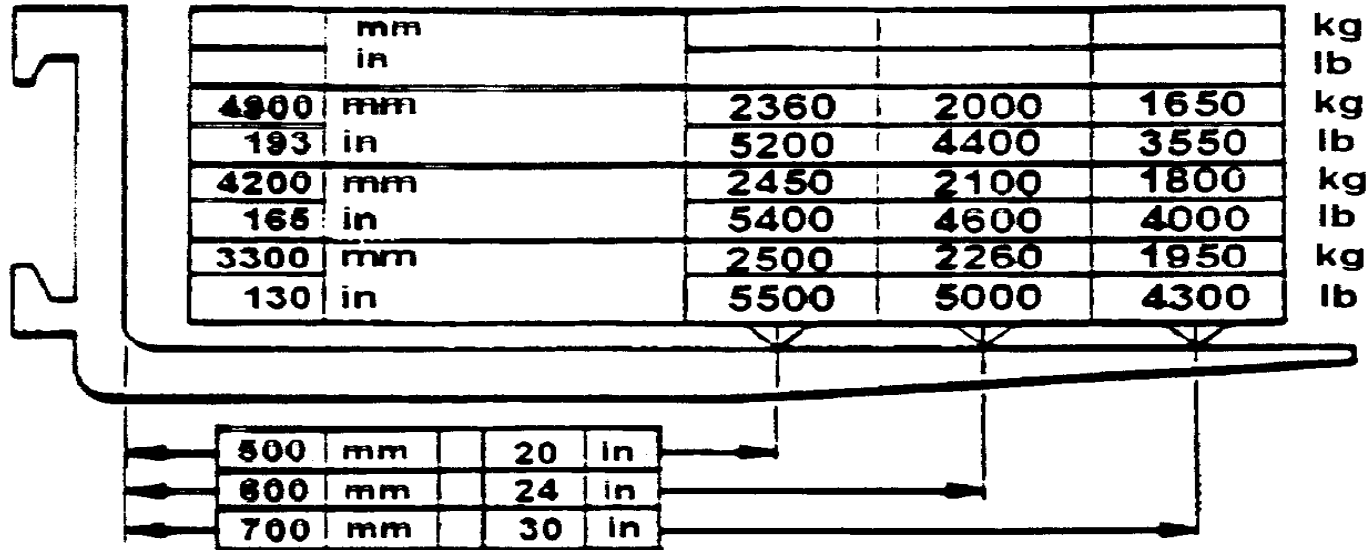

The diagram shows a side view of a forklift mast. The capacity table is integrated into the mast structure. Below the table, three horizontal arrows point to the right, indicating the reach for different mast heights: 500 mm (20 in), 600 mm (24 in), and 700 mm (30 in). The mast is supported by a base with two lifting points.

**CAPACITIES APPLY WITH MAST VERTICAL, LOAD CENTRAL AND EVENLY DISTRIBUTED ON STANDARD FORKS**

# Rated Capacity Plates & Safe Working Loads

**In the example below the lift truck is rated at 1800kgs @ 500mm load centre**

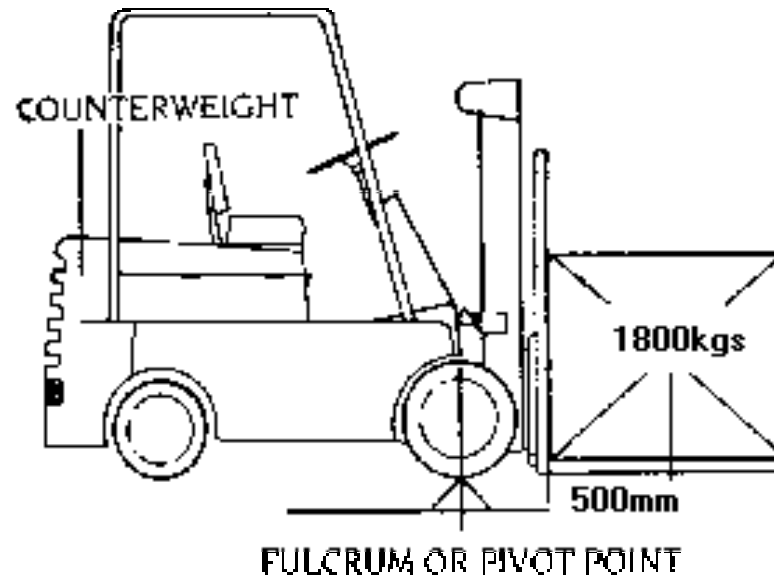

# Rated Capacity Plates & Safe Working Loads

The lift truck below has a load centre of 600mm. How much weight can the lift truck lift?

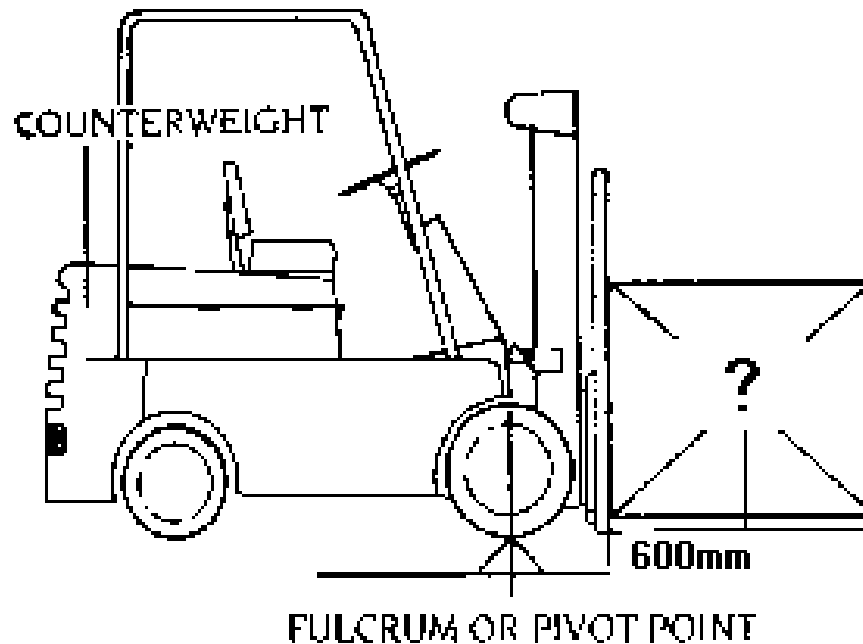

# Rated Capacity Plates & Safe Working Loads

Multiply the SWL (1800kgs) by its load centre (500mm) then divide by the new load centre (600mm)

$$\begin{array}{r} \text{1800} \\ \times \text{500} \\ \hline \div \text{600} \\ \hline = \text{1500} \end{array}$$

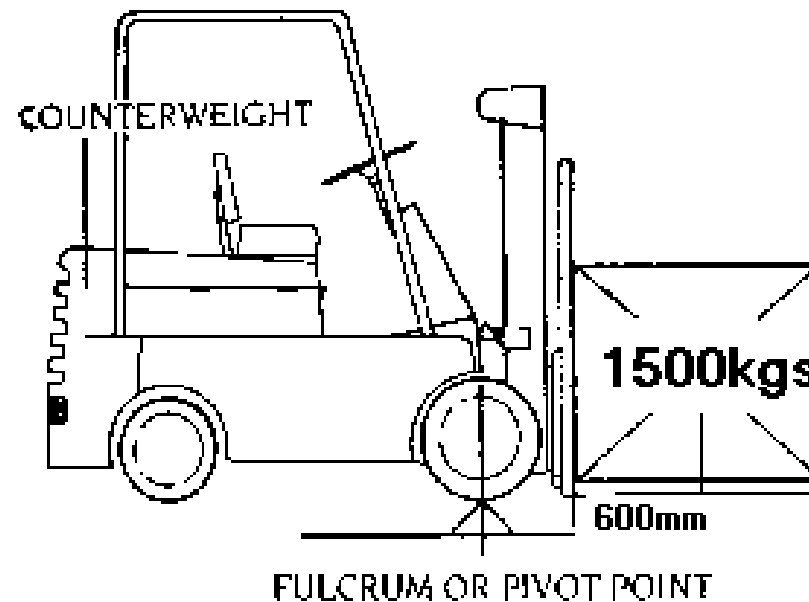



---

Have you any questions so far?

# Lift Truck In-Stability

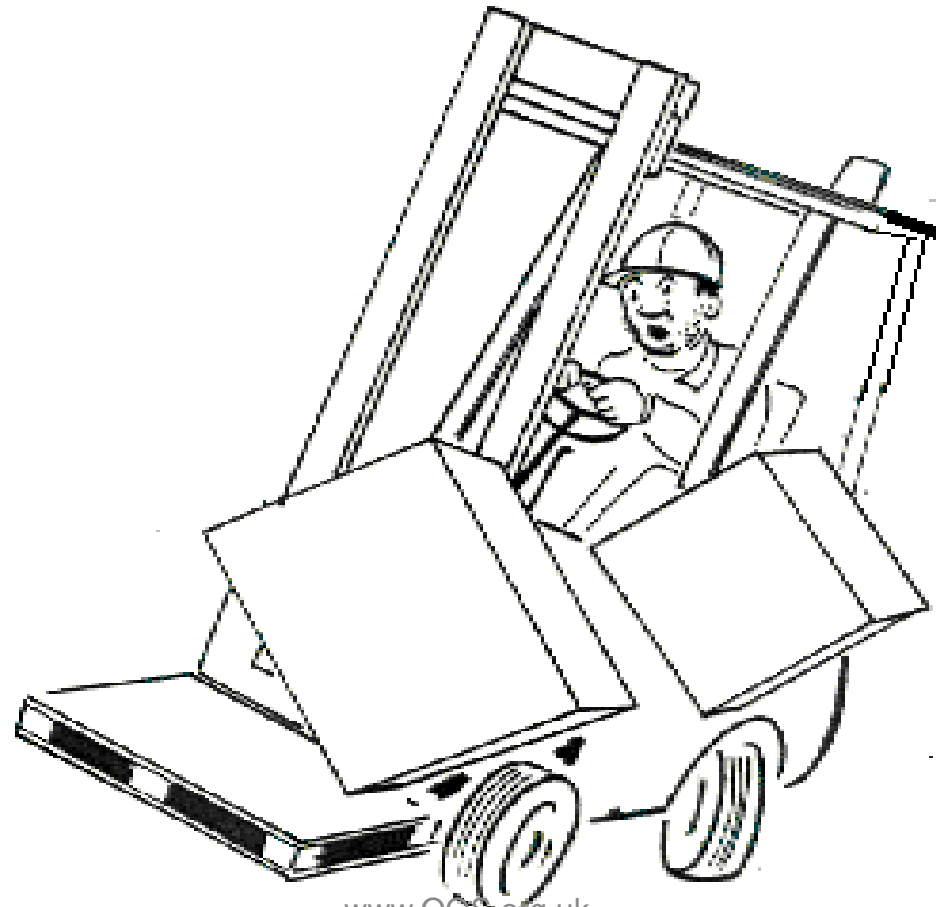

# Lift Truck Stability

## THE NATURAL AXES OF LIFT TRUCKS

The stability of a lift truck is designed to allow for uneven ground. It is vital that the steering axle is pivoted at its centre. This gives the lift truck the same stability characteristics of a wheel barrow, a triangular area of great stability narrowing at one end (C).

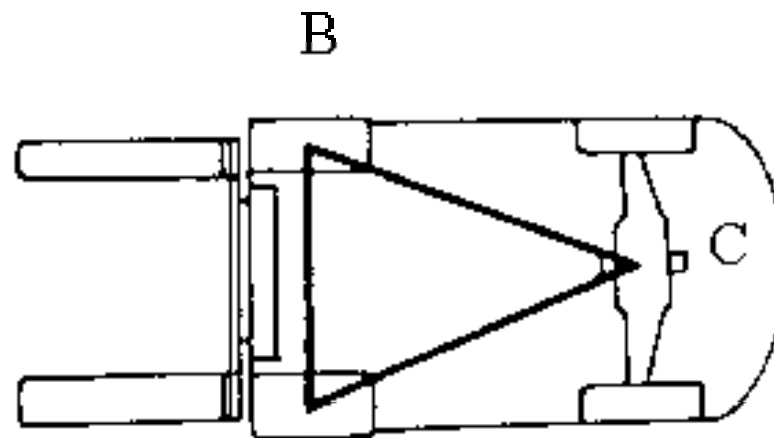

# Lift Truck Stability

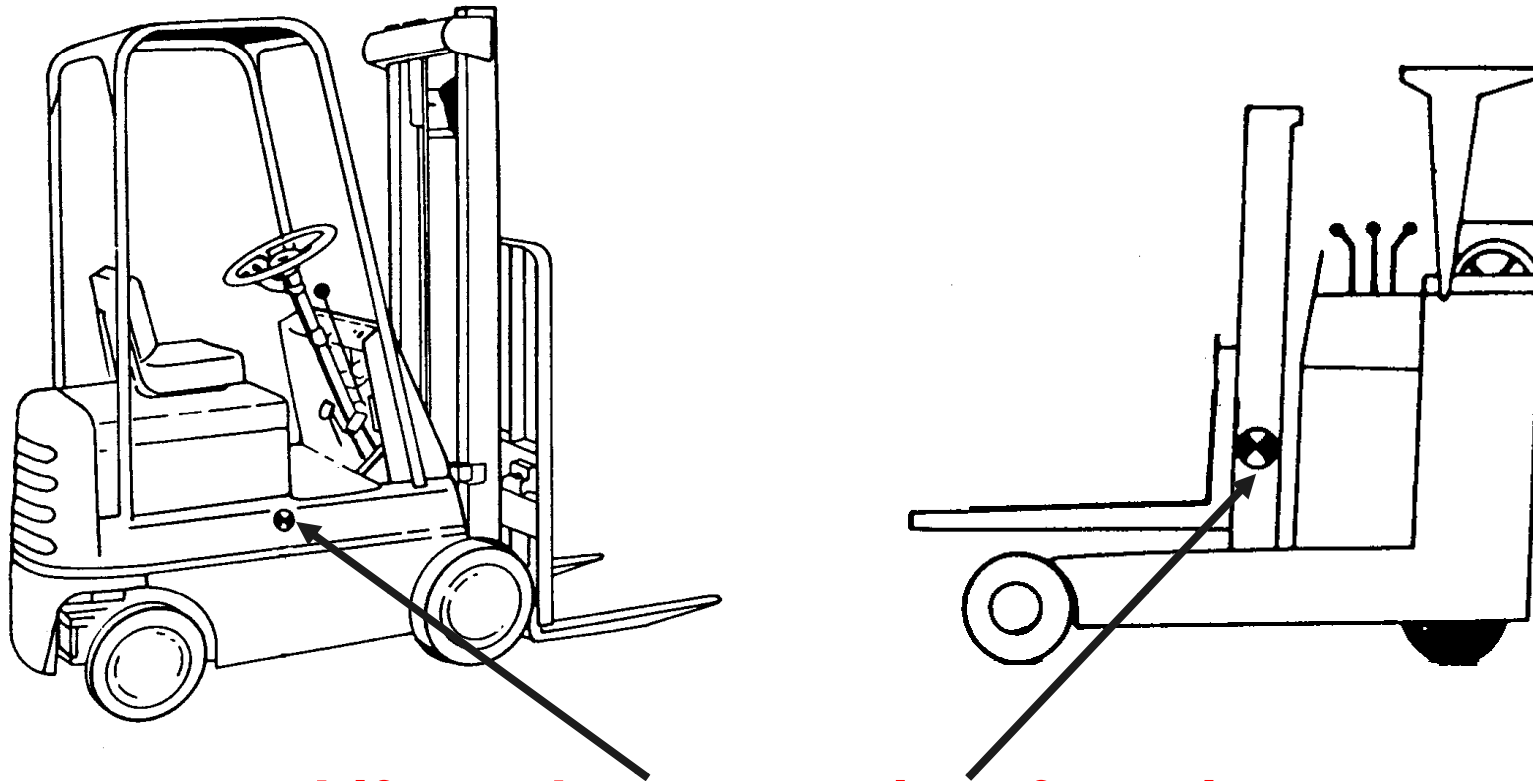

**Lift truck centre point of gravity**

# Lift Truck Stability

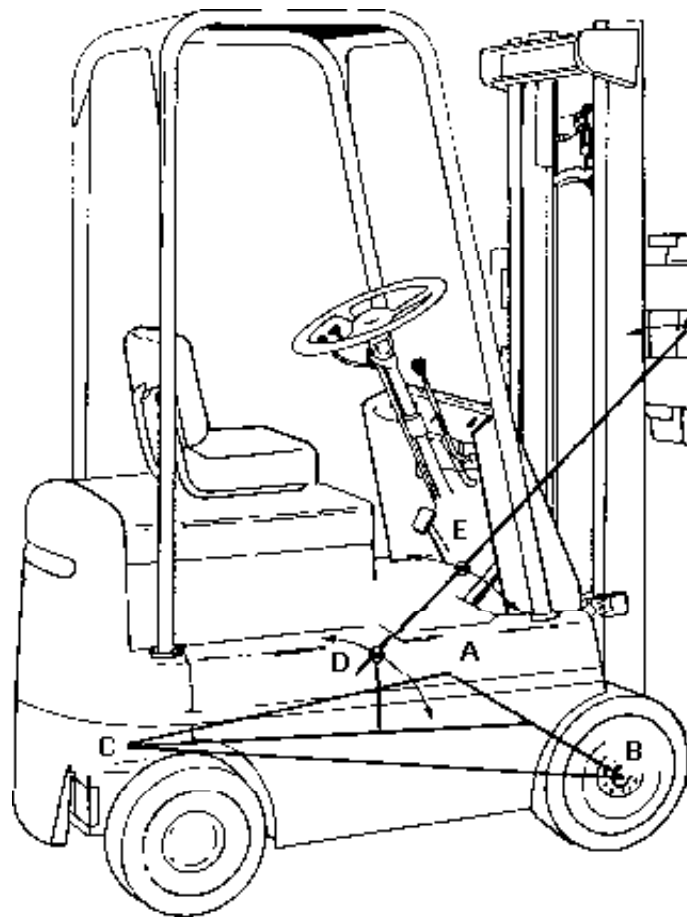

**The lines between points C and A and between C and B are called “the lines of side support”.**

**The truck will tip sideways if its centre point of gravity of the truck moves out of the points between C and A and C and B.**

**The truck will tip forwards if its centre point of gravity moves out of line E.**

# Lift Truck Stability

## Causes of Longitudinal Instability (forwards).

**Exceeding the trucks maximum WLL (weight).**

**Exceeding the load centre to weight ratio (undercutting, having the weight too far forwards on forks).**

**Exceeding the height to weight ratio (travelling with a raised load).**

**Travelling in the wrong direction on an incline laden.**

**Sudden braking.**

**Misuse of forward tilt.**

**Live load.**

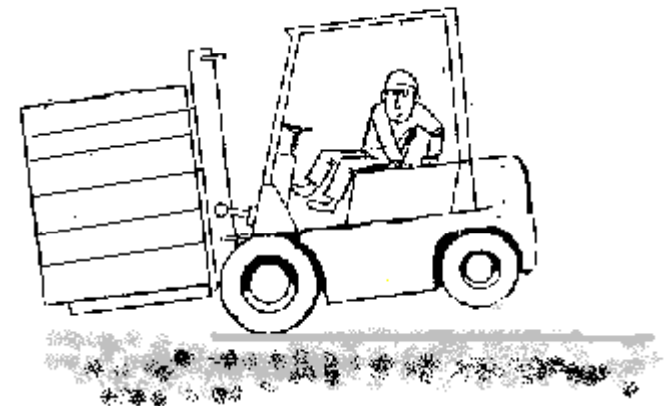

# Lift Truck Stability

## Causes of Lateral Instability (sideways).

**Tyres (incorrect tyre pressure, uneven wear on solid tyres).**

**Turning at speed. (Turning sharply).**

**Turning on an incline.**

**Hitting an obstruction (ground conditions).**

**Excessive backward tilt at height**

**Uneven load. Live load. Lifting on one fork.**

**Incorrect use of side shift.**

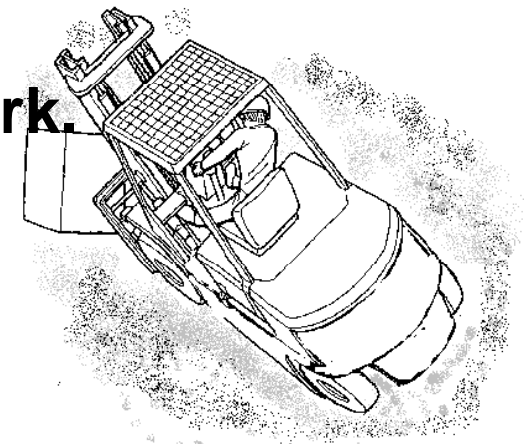



---

Have you any questions so far?

# OPERATORS SAFETY CODE

## WHY?

To prevent accidents by the habitual use of safe working practices.

## ACCIDENTS?

An unexplained unexpected event, which could produce: -

- DAMAGE
- INJURY
- DEATH

# OPERATORS SAFETY CODE

## **SAFETY?**

**Being free from hazard & risk.**

## **HAZARDS?**

**The conditions creating risk of accident.**

**Removing the hazard automatically removes the risk.**

**Where the hazard cannot be removed care and necessary action must be taken at all times.**

# OPERATORS SAFETY CODE

## HOW IS SAFETY ENSURED?

By obeying the  
**OPERATOR,**  
**MANUFACTURERS**  
and  
**COMPANY**  
**SAFETY CODE.**

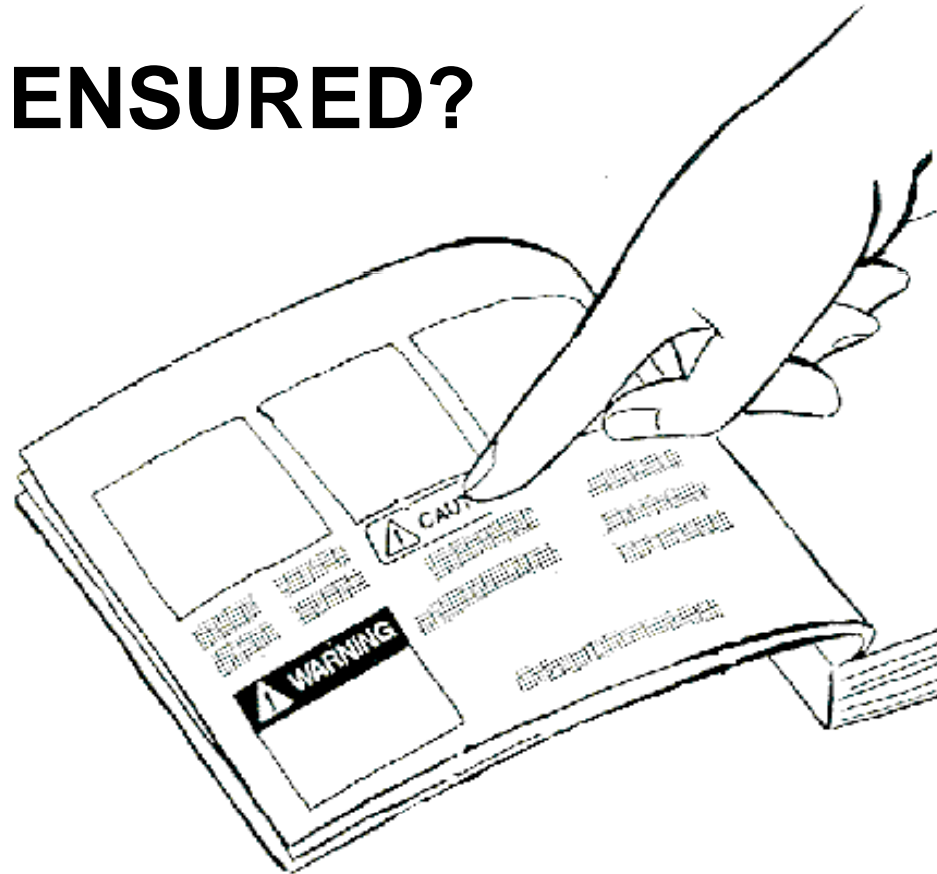

# OPERATORS SAFETY CODE



**The operator is responsible for checking that the lift truck is in good working order before using it.**

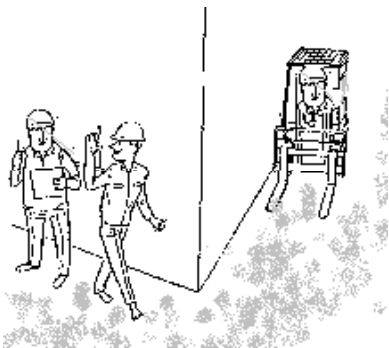

**The lift truck operator is responsible to ensure the safety of pedestrians while operating a lift truck.**

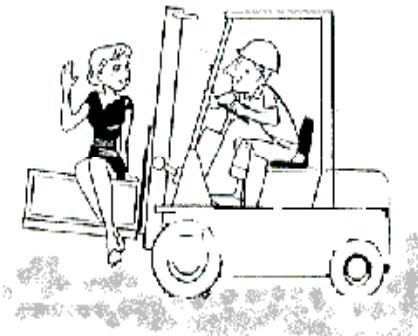

**The operator must not allow anyone to travel on the FLT or any part of the FLT unless the truck has been designed for that purpose.**

# OPERATORS SAFETY CODE

**Do not allow anyone to stand or walk under raised forks.**

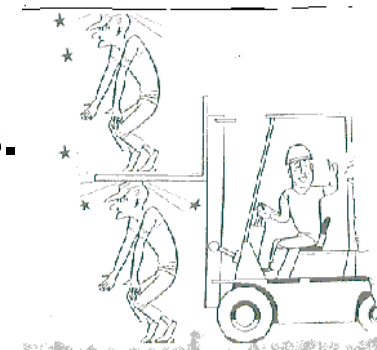

**When leaving a FLT unattended ensure: -**

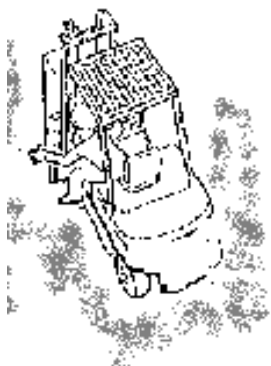
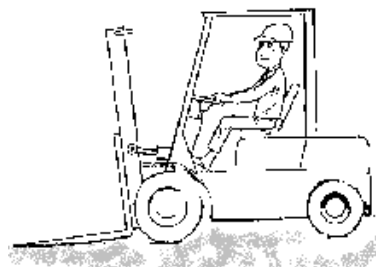
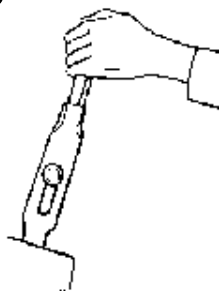

**Keep hands and feet within the confines of the FLT.**

# OPERATORS SAFETY CODE

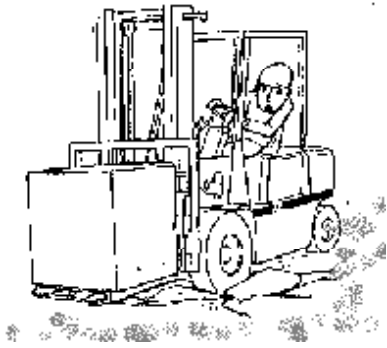

Changes in ground surfaces such as wet/dry, icy or greasy, very smooth, loose surface; inclines, railway lines or gullies can cause instability, loss of adhesion/braking, damage or loss of load. Always drive across railway lines, drainage gullies etc slowly and, if possible, diagonally.

Travel at a speed consistent with the type of load and general working conditions.

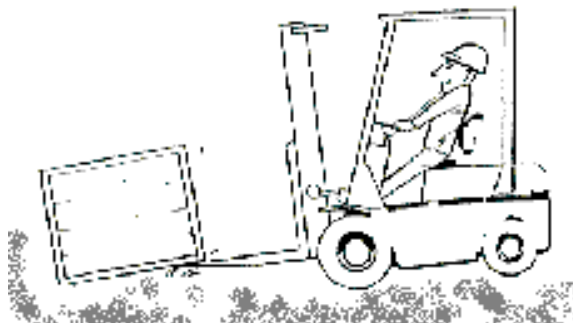

Do not make fast starts or sudden stops.

# OPERATORS SAFETY CODE

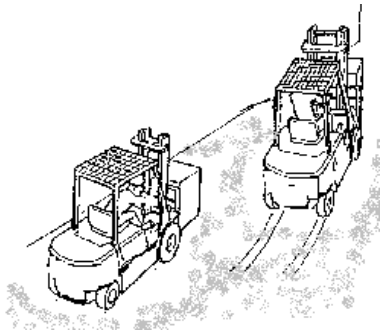

**Slow down at intersections and corners and do not overtake any other vehicle at these points**

**Sound the horn (few sharp blasts) when approaching intersections, corners or any blind spots and if possible drive wide to increase visibility  
When turning ensure there is enough room for the rear and front end swing.**

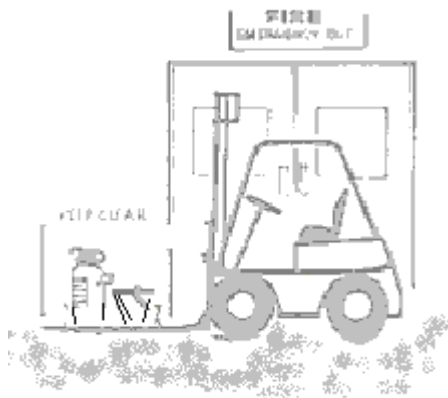

**Do not park an industrial lift truck near doorways, switches and electricity boards, fire fighting equipment, blind corners, on inclines, loading bays wet or muddy areas, soft ground or generally in the way.**

# OPERATORS SAFETY CODE



**If there is oil or fuel spillages clean them up.**



**Always look in the direction of travel and have a clear view of the way ahead and be aware of overhead obstructions; be sure there is enough room for safe operations.**



**X**



**When following another truck keep a minimum of three truck lengths from the truck in front.**

# OPERATORS SAFETY CODE

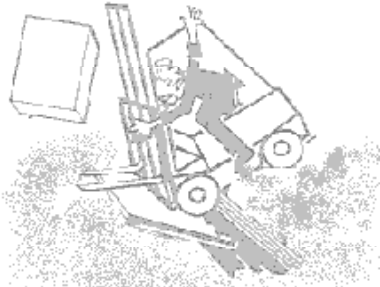

**Check before entering lifts or driving over dock levellers or bridge plates that they are safe and able to take the combined weight of the FLT and load.**



**If a fault occurs on the fork truck stop immediately and seek assistance.**

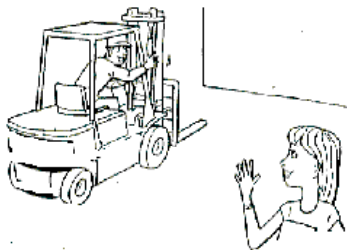

**Do not be distracted and there must be no skylarking or practical jokes when operating a FLT.**

# OPERATORS SAFETY CODE

**Before moving off with a lift truck in any direction the last thing the operator must do is look around.**



**The safest procedure when preparing to move off is select transmission, look around, hand brake off then move.**



**In normal circumstances, if the load on the forks obscures your view you should travel in reverse, looking in the direction of travel (except when travelling up a hill then get someone to guide you).**

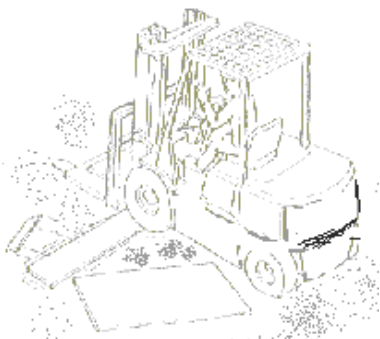

**While operating a lift truck if you saw some rubbish/dunnage laying in a gangway or warehouse location park the truck in a safe place and remove the obstruction.**

# OPERATORS SAFETY CODE

## Inclines:

When laden the load must face up the incline.

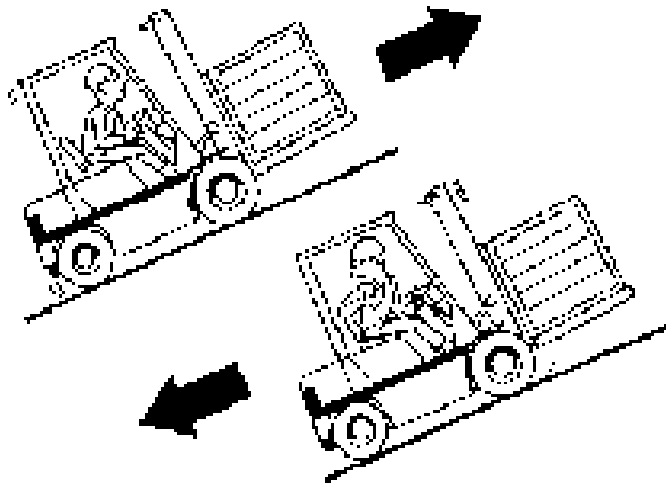

When un-laden the forks must face down the incline.

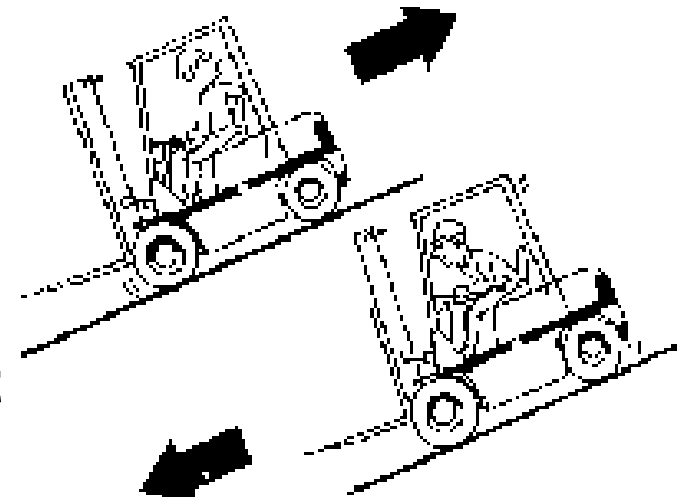

When an un-laden truck is being driven on a gradient to improve stability, traction and adhesion the forks should face downhill.

# OPERATORS SAFETY CODE

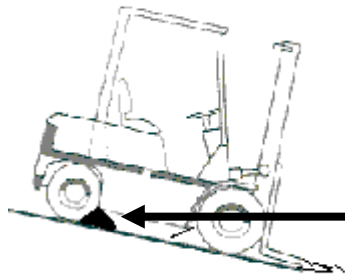

**If a lift truck has to be parked on an incline leave it in the correct parked position and chock the wheels.**



**Do not drive or operate a lift truck across inclines as this will reduce sideways stability and the lift truck has a strong possibility to overturn.**



**When driving an un-laden truck the forks should be set as low as practicable and tilted back.**

# OPERATORS SAFETY CODE

WARNING - DO NOT OVERLOAD

Lift	Load		
	mm	kg	lb
4900	2380	2000	1650
1931	5200	4400	3550
4200	2450	2100	1800
168	3400	4600	4000
3300	2500	2250	1950
130	5500	5000	4300

Lift	mm	in
800	24	30
600	18	24
700	21	30

CAPACITIES APPLY WITH MAST VERTICAL, LOAD CENTRAL AND EVENLY DISTRIBUTED ON STANDARD FORKS

**Rated capacity plates should clearly indicate the weight the lift truck can lift, to what load centre and what height.**

**Never exceed the lift truck rated capacity.**

**To comply with the manufacturers stated lifting capacity the lift truck's mast must be vertical with the truck on level ground.**



**Before picking up a load check its weight, load centre, the height which the load has to be placed and its condition and security.**

**To work out how much weight your lift truck can safely lift at various load centres times the safe working weight the truck can lift by its relevant load centre then divide by the new load centre.**

# OPERATORS SAFETY CODE

The term “load centre” is the measurement given forward from the front face of the fork arms to the centre point of gravity of the load.

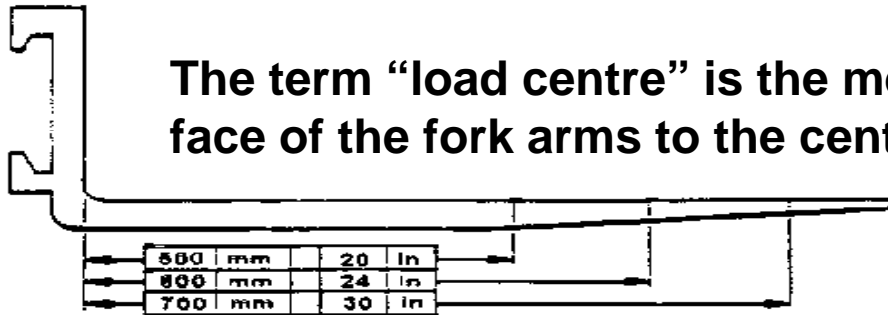

The trucks maximum capacity will be reduced when the load centre is increased.

If a side shift is fitted to a lift truck it may reduce the lift trucks lifting capacity, it may reduce visibility, stability and it will require to be repositioned (centrally) after use.

# OPERATORS SAFETY CODE



**The load centre will be increased when tilting a load forward at height.**

**Never use the full range of tilt at Height laden or un- laden.**

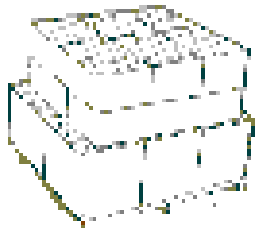

**Net weight = the weight of the load.**

**Gross weight = the weight of the load and the pallet.**

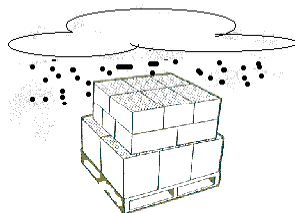
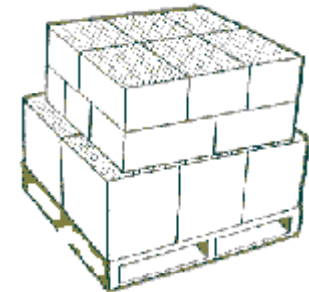

**In winter months loads stacked outside may be covered in ice and snow, the effect of this will increase the weight of the load.**

# OPERATORS SAFETY CODE

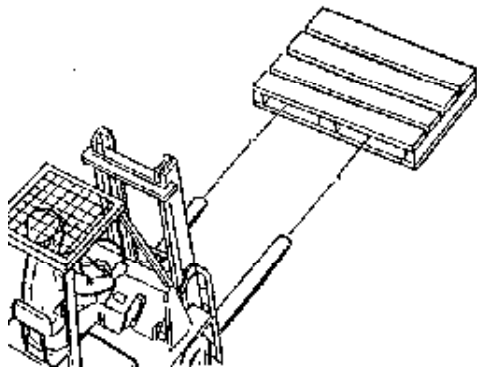

**Ensure the fork arms are set so that they are able to take equal weight on each fork before entering a palletised load.**

**When handling metal stillages the forks must be positioned as wide as possible to prevent the load slipping sideways.**



**Apply the parking brake and place into neutral before using any hydraulic controls to ensure the lift truck is stable during the operation of the hydraulic controls and the operator will be able to concentrate on the stacking/destacking operation.**

# OPERATORS SAFETY CODE

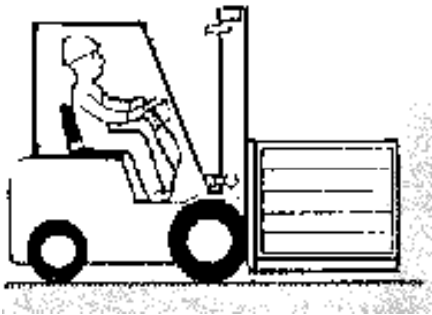

**When picking up a load ensure it is fully heeled to ensure the load centre is as short as possible to maintain stability, to keep the truck and its load as short as possible for confined areas and to maintain load stability against the fork arms and carriage unless undercutting the load is required.**

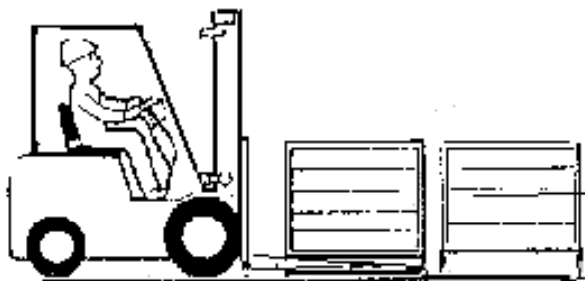

**Undercutting is used when the forks are longer than the pallet and the pallet is adjacent to a wall or another pallet or the pallet cannot be heeled up immediately. Be aware when undercutting of the weight – load centre ratio.**

# OPERATORS SAFETY CODE

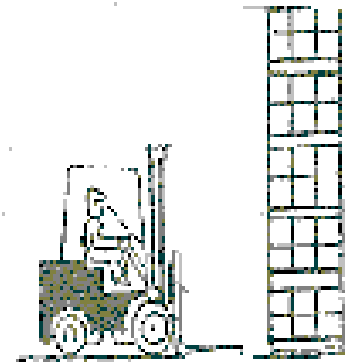

**When stacking or destacking stop approximately 150mm from the stack/load/rack, apply the parking brake: select neutral before operating the hydraulic controls, adjust the tilt and raise the forks/load.**

**By stopping approximately 150mm from the stack/load/rack will assist the operator with accuracy, reduce damage and discourage persons walking in-between the lift truck and stack/load/rack.**



**Apply sufficient back tilt to cater for the type of load and ground conditions when transporting a palletised load. Never use the full range of tilt with the forks raised laden or unladen (100-150mm).**

# OPERATORS SAFETY CODE



**The meaning of “free lift “in connection with lift trucks is the distance the forks can be raised before the mast begins to extend.**



**When sounding the horn make several short blasts.**

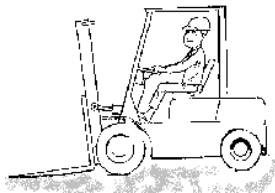

**When parking a lift truck the heels of the forks should be as low as possible and the tips touching the ground.**

# Survive a TIPOVER

**DO NOT:** try and jump clear of a FLT that is tipping

**DO:** Hold firmly onto the steering wheel

Brace your feet

Lean away from the impact

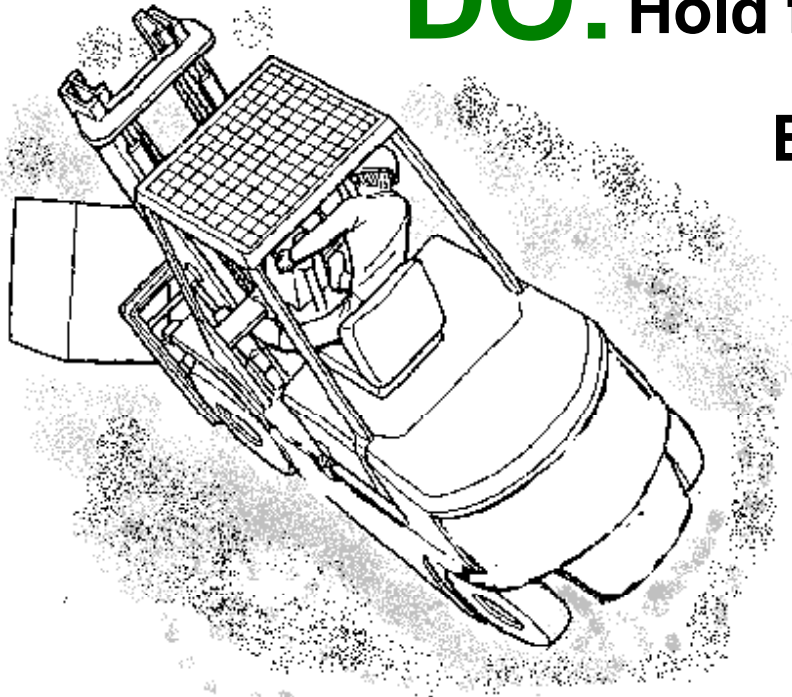

# ADDITIONAL RULES FOR REACH TRUCKS

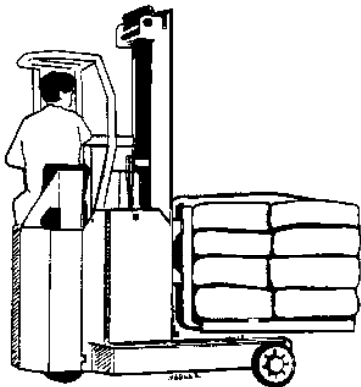

**Travel truck first whether laden or unladen except when positioning the truck to deposit a load or when travelling on inclines laden.**

**When laden the load should be positioned approximately 50mm above the reach legs, fully reached back with backward tilt applied.**

**When un-laden the forks should be positioned below the reach legs with backward tilt applied.**

**Do not use the reach legs to push loads into position.**

**Never park the truck with the reach left out.**



---

Have you any questions so far?

# Vehicle Loading and Unloading

**Before loading or unloading a flat bed or curtainsider lorry ensure: -**

- **the vehicle is on flat firm ground.**
- **the driver has applied the parking brake chocked the wheels (if applicable).**
- **the engine is switched off.**
- **he/she is aware of your intentions.**
- **the bed of the lorry is in good conditions.**

# Vehicle Loading and Unloading

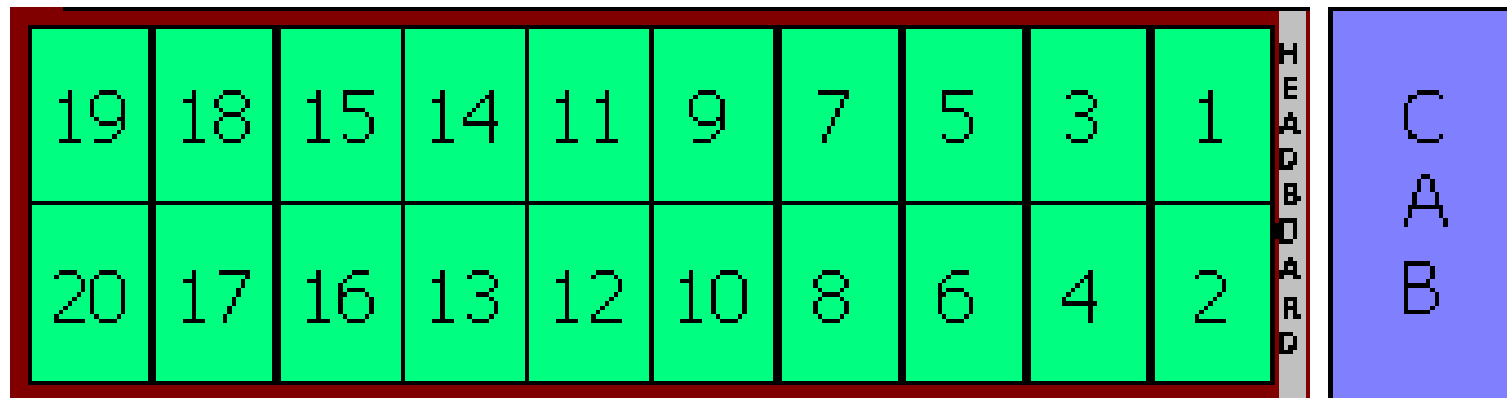

**When loading a lorry it is important that loaded pallets are placed tight to one another and against the headboard (behind cab) to reduce load movement in transit especially when the lorry is braking and to ensure the lorry will take a full load.**

# THE USE OF LT's AS AN (EWA) WORKING PLATFORM.

The use of trucks to support working platforms is **in direct contravention of the Health & Safety at Work Act unless certain precautions are taken.**

If a LT is to be used in this manner then an approved safety cage should be used.

Before using a safety cage (manned platform) ensure it is serviceable and complies with LOLER requirements suited to the lift truck to be used with, it is secured to the lift truck using the correct method, there is a safe method of use agreed before using the safety cage, only authorised persons are lifted in the safety cage and hard hats are worn where required.

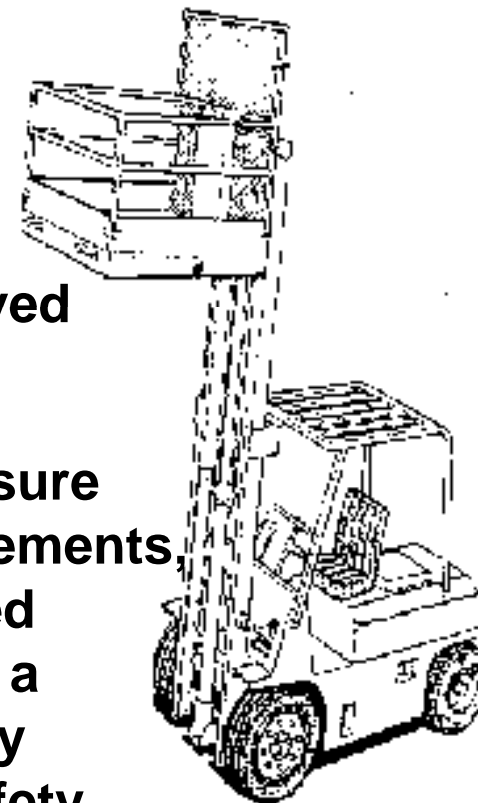



---

Have you any questions so far?

# DAILY / PRE-SHIFT CHECKS

**Visual Checks:** To ensure components are not damaged.

**Operational checks:** To ensure all mechanical, hydraulic and electrical parts are working correctly.

**Log Sheet / Form:** Used daily by the operator to note any faults both visual & operational. This form should be signed by a supervisor or manager daily bringing to their attention any faults with the truck.

The completed form should be available for any other operator who may be required to operate the truck within the working day.

# DAILY / PRE-SHIFT CHECKS

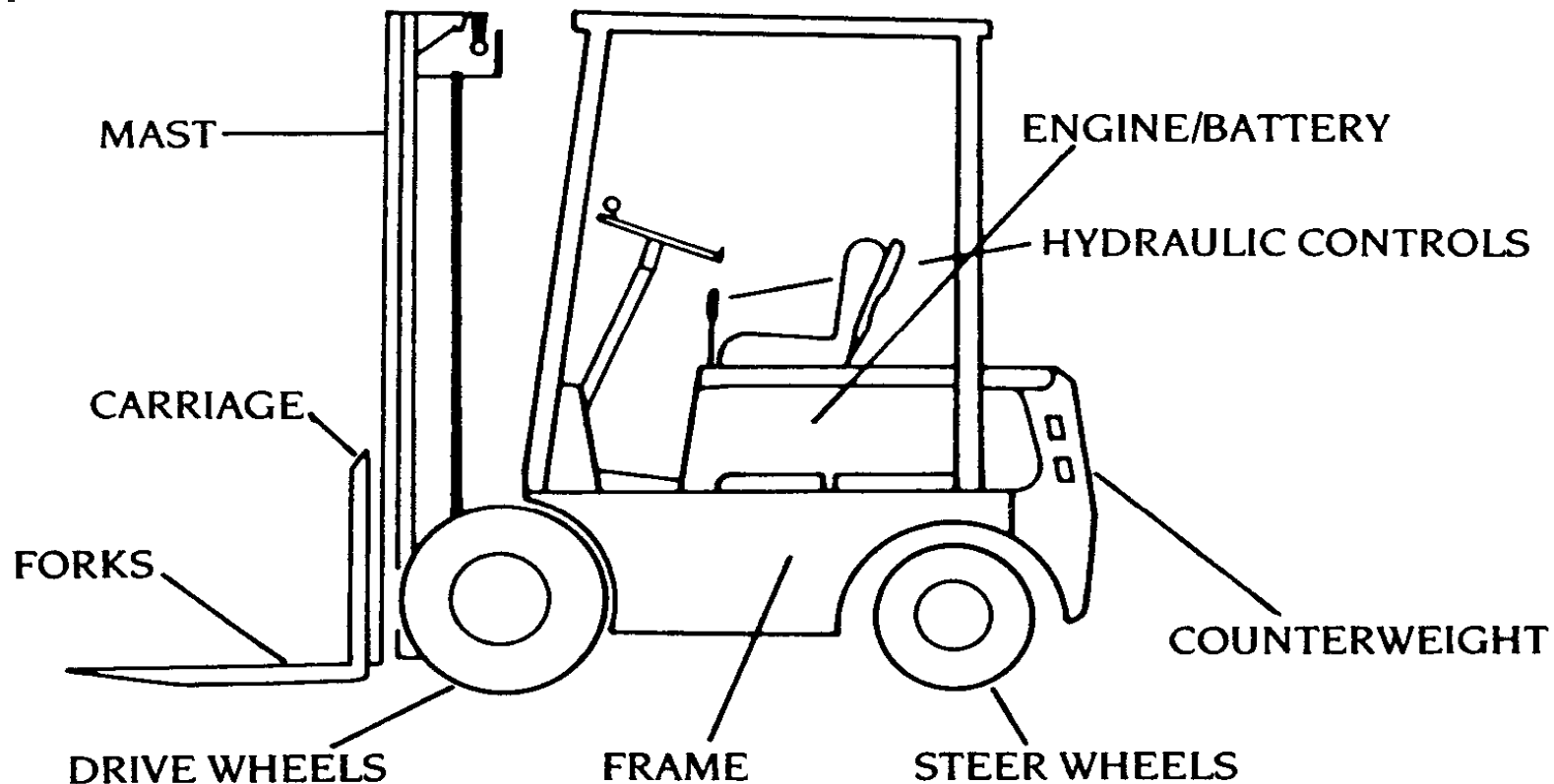

**REMEMBER IF A FAULT OCCURS AT ANY TIME THEY  
MUST BE REPORTED IMMEDIATELY.**

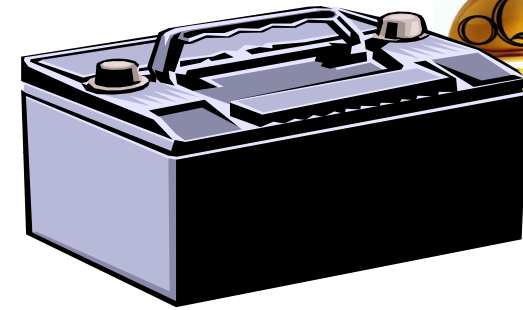

# BATTERY CARE



**Check that there are no sources of ignition, naked flames, cigarettes etc.**



**Electrolyte: Mixture of distilled water and sulphuric acid when charging gives off a highly explosive gas.**

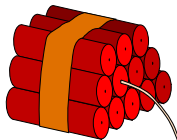

**Always disconnect the battery from the charger before checking and topping up.**

**Do not wear jewellery, watches etc. When checking the battery.**

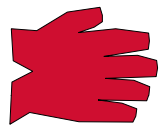

**PPE: Gloves, goggles and an apron must be worn when checking the electrolyte level. Eye wash solution must be at hand.**

**After topping battery clean battery surface and discard rags used.**

**Batteries should only be charged in well-ventilated places. Open the battery covers but do not open the filler caps when recharging.**

# REFUELLING DIESEL / PETROL TRUCKS



**Never refuel a truck with the engine running.**

**Take care not to over fill. Wipe away any spillages and replace filler cap tightly.**



**Never use a naked flame when refuelling or checking fuel levels and Check that there are no sources of ignition, naked flames, cigarettes etc.**

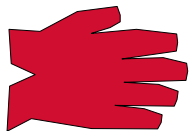

**PPE: Always wear suitable gloves when refuelling.**

**It is advisable to refuel at the end of each shift to reduce the risk of condensation forming in the fuel tank overnight.**



# CHANGING L.P.G. CYLINDERS

LPG cylinders should only be changed in the open air or in well ventilated places.

Check that there are no sources of ignition, naked flames, cigarettes etc.



Switch off any power tools that may be in the vicinity.

PPE: Eye, hand and foot protection must be worn when changing LPG cylinders.

# CHANGING L.P.G. CYLINDERS



**Shut off the hand valve and then unscrew the connector. Check the connector to ensure the cylinder-sealing washer has lodged in the connector. Move the connector and hose clear of the cylinder if necessary tuck it out of the way. Release the strap(s) holding the cylinder. To the truck, note the position of the cylinder.**

**Remove the cylinder and place it in the LPG cylinder storage area.**

**Keep empty cylinders in a different storage area to the full ones.**

**Check the new cylinder is the correct type and all fittings are compatible and in good condition.**

**Place the full cylinder onto the cradle and ensure it is positioned correctly. (Arrow on bottom of cylinder).**

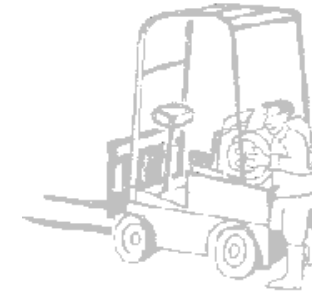

# CHANGING L.P.G. CYLINDERS

**Check the condition of the coupling and hose and make sure the cylinder-sealing washer is in place. Screw the connector to the cylinder making sure it is tight. (by hand).**

**Slowly open the hand valve. The gas will be heard hissing into the system and it may take a few moments to fill.**

**In the event of a problem with a cylinder for example gas leaking or the gas not getting through to the system switch off the hand valve before investigating further. Do not drop or roll cylinders along the ground LPG cylinders contain gas under considerable pressure so treat them carefully.**



---

Have you any questions?

About the theory aspect of  
Lift Truck Operating!